



LORING™

The Smarter Way to Roast

LORING™ S35 Falcon™

Automated 35 kg Roaster

INCLUDES

- Touchscreen interface
- Green bean vacuum lift
- Automation software with auto-charge and discharge of beans
- High speed cooling tray with paddle stirring
- Green bean cart with scale
- 7-35 kg batch capacity

OPTIONAL

- Destoner



ROASTER SPECIFICATIONS

Maximum Batch Size	77 lb (35 kg)
Maximum Batch Size	15.4 lb (7 kg)
Nominal Electrical Power ¹	3.8 kW
Peak Electrical Power ²	7.2 kW
Maximum Operational BTU Rating	310,000 BTU/h (78,200 kcal/h)
Maximum Instantaneous BTU Rating	350,000 BTU/h (88,300 kcal/h)
Stack Temp Continuous ³	1,400°F (760°C)
Stack Temp Intermittent ⁴	1,600°F (870°C)
Stack Flow Continuous ⁵	52 dscfm (88 dsm ³ /h)
Stack Max Flow (Peak Air Cool) ⁶	450 dscfm (765 dsm ³ /h)
Stack Duct Diameter (Minimum)*	8 in (203 mm)
Cooler Vent Max Flow	1,200 scfm (2,035 sm ³ /h)
Cooler Duct Diameter*	8 in (203 mm)
Water Supply (Flow) Minimum	2.5 GPM (9.5 liter/min)
Water Pressure Minimum	40 psi (276 kPa)
Natural Gas Pressure	4-7 in WC (1.0-1.7 kPa)
Propane Gas Pressure	11-13 in WC (2.7-3.2 kPa)
Weight ⁷	2,190 lb (993 kg)

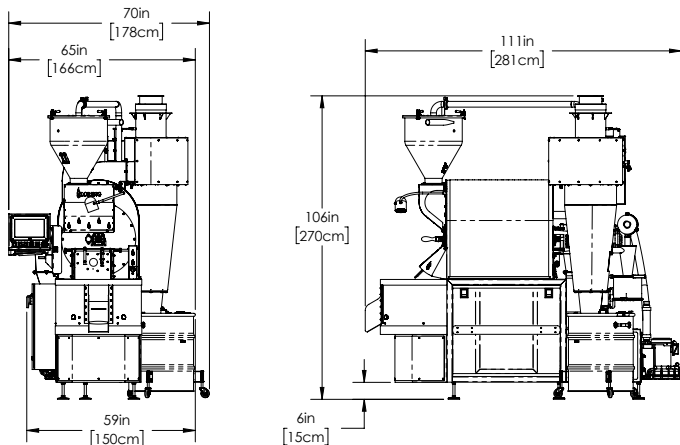

* Larger stack diameters may be required based upon stack geometry. 1 Loring defines Nominal Electrical Power as the power the roaster consumes during typical use. 2 Loring defines Peak Electrical Power as the power the roaster will consume if all roaster operations are run simultaneously. 3 Loring defines the continuous temperature rating as the temperature which the machine can reach and maintain when roasting at the high end of its capability. 4 Loring defines the intermittent temperature rating as the maximum temperature that the machine cannot exceed during a roast. 5 Dry, or water content of the flue removed, under standard pressure and temperature conditions. 6 Add Stack Max Flow (Peak Air Cool) and Cooler Vent Max Flow to obtain the total airflow out of the building. 7 Uncrated weight. Exact system weight may depend on options selected.

SUPERIOR IS OUR *STANDARD.*

Engineered for a roasting experience like no other, every Loring machine gives you unmatched quality, unheard-of efficiency, and unparalleled control.



UNMATCHED QUALITY.

- Designed and made in U.S.A.
- Constructed by skilled craftsmen.
- Stainless steel construction.
- ISO 9001:2015 Certified.

UNPARALLELED CONTROL.

- Touch screen and PID provide operation of burner and fan speeds.
- Profiles can be saved and repeated consistently.
- Fully automated roasting process.

UNHEARD-OF EFFICIENCY.

- Single burner roasts beans and incinerates smoke.
- High-speed cooling tray reduces cooling time while protecting beans.
- Up to 80% fuel-savings
- and reduction of greenhouse gases in every roast, compared to conventional roasters.

Contact Us

Loring Smart Roast, Inc.
3200 Dutton Avenue, Suite 413
Santa Rosa, CA 95407
+1 707 526 7215

Australia, New Zealand
CT ROASTING SOLUTIONS
Adelaide, South Australia
+61 0400 250 598
lachlan@ctroastingsolutions.com.au

China (PRC), Hong Kong
SHANGHAI FORTUNECAFFE CO.
Shanghai, China
+86 21 6249 9786
sales@fortunecaffe.com

Europe, Middle East, Africa, Pakistan
THE COFFEE ROASTING COMPANY APS
Copenhagen, Denmark
+45 3023 8775
jht@thefactorycoffee.eu

India
ANURATI
Bangalore, India
+91 98455 78935
srinivas@anurati.ch

Indonesia
PT. MESIN KAFE DAN SERVICE
Jakarta, Indonesia
edward@mesinkafe.com

Japan, Taiwan
DCS CO., LTD
Osaka, Japan & Taipei, Taiwan
+81 798 35 2980
www.dcservice.co.jp
www.dcs-asia.com

Korea
M.I. COFFEE CORPORATION
Seoul, South Korea
+82 592 0167
mi@micoffee.co.kr

North America, Latin America
ZENDEUS
San Francisco, California
+1 415 374 9097
duncan.elcombe@zendeus.com

Singapore
CAFE N ALL PTE LTD
Singapore
gracia@cafenall.com

Southeast Asia
BARISTA JAM
+6684 644 3344
meechoke@baristajam.coffee

Thailand
UCC K2 COMPANY LTD.
Bangkok, Thailand
+66 2276 5170
sales@ucck2.co.th

SCHEDULE A DEMO OR REQUEST A QUOTE AT LORING.COM



© 2026 Loring Smart Roast, Inc. The following are trademarks of Loring Smart Roast, Inc.: Loring, The Smart-er Way to Roast, S7 Nighthawk, S15 Falcon, S35 Kestrel, S70 Peregrine, and the flame symbol. Users are responsible for verifying that they are using the latest document revision available. Loring reserves the right to make changes to this document at any time without notice. 1002696 Rev. P