

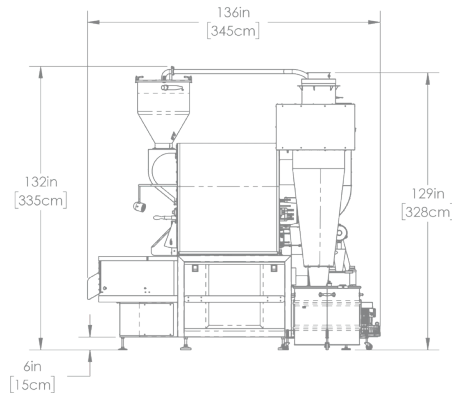

LORING

The Smarter Way to Roast

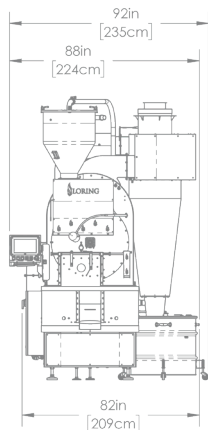

LORING™ S70 Peregrine™ Automated 70 kg Roaster

INCLUDES

- Touchscreen interface
- Green bean vacuum lift
- Automation software with auto-charge and discharge of beans
- High speed cooling tray with paddle stirring
- Green bean cart with scale
- 14-70 kg batch capacity

OPTIONAL

- Destoner
- Cooler tray auto-discharge gate

ROASTER SPECIFICATIONS

Maximum Batch Size	154 lb (70 kg)
Minimum Batch Size	30.8 lb (14 kg)
Nominal Electrical Power	8.6 kW
Peak Electrical Power	17.5 kW
Maximum BTU Rating	620,000 BTU/h (156,341 kcal/h)
Stack Temp Continuous ¹	1,400°F (760°C)
Stack Temp Intermittent ²	1,600°F (870°C)
Stack Max Flow	107 dscfm (182 dsm ³ /h)
Stack Max Flow (Peak Air Cool)	950 dscfm (1,614 dsm ³ /h)
Stack Duct Diameter (Minimum)*	10 in (254 mm)
Cooler Vent Max Flow	2,180 scfm (3,704 sm ³ /h)
Cooler Duct Diameter*	10 in (254 mm)
Water Supply	1 GPM (4 liter/min)
Water Pressure	50 psi (345 kPa)
Compressed Air Flow	4 CFM (0.1 m ³ /h)
Compressed Air Pressure	80 psi (552 kPa)
Natural Gas Pressure	4-7 in WC (1.0-1.7 kPa)
Propane Gas Pressure	11-13 in WC (2.7-3.2 kPa)
Weight	3,900 lb (1,769 kg)

*Larger stack diameters may be required based upon stack geometry

1 Loring defines the continuous temperature rating as the temperature which the machine can reach and maintain when roasting at the high end of its capability.

2 Loring defines the intermittent temperature rating as the maximum temperature that the machine cannot exceed during a roast.

SUPERIOR IS OUR STANDARD.

Engineered for a roasting experience like no other, every Loring machine gives you unmatched quality, unheard-of efficiency, and unparalleled control.



UNMATCHED QUALITY.

- Designed and made in U.S.A.
- Constructed by skilled craftsmen.
- Stainless steel construction.
- ISO 9001:2015 certified.

UNPARALLELED CONTROL.

- Touch screen and PID provide operation of burner and fan speeds.
- Profiles can be saved and repeated consistently.
- Fully automated roasting process.

UNHEARD-OF EFFICIENCY.

- Single burner roasts beans and incinerates smoke.
- High-speed cooling tray reduces cooling time while protecting beans.
- Up to 80% fuel-savings and reduction of greenhouse gases in every roast, compared to conventional roasters.

Contact Us

Loring Smart Roast, Inc.

Santa Rosa, CA
+1 707 526 7215
sales@Loring.com
www.Loring.com

North America, Latin America

ZENDEUS
San Francisco, California
+ 1 415 374 9097
duncan.elcombe@zendeus.com

Australia, New Zealand

CT ROASTING SOLUTIONS
Adelaide, South Australia
+61 400 250 598
lachlan@ctroastingsolutions.com.au

India

ANURATI
Bangalore, India
+91 98455 78935
srinivas@anurati.ch

Thailand

UCC K2 COMPANY LTD.
Bangkok, Thailand
+66 2276 5170
sales@ucck2.co.th

Southeast Asia

BARISTA JAM
+6684 644 3344
Meechoke@BaristaJam.coffee

China (PRC), Hong Kong

SHANGHAI FORTUNECAFFE CO.
Shanghai, China
+86 21 6249 9786
sales@fortunecaffe.com

Japan, Taiwan

DCS CO., LTD
Osaka, Japan & Taipei, Taiwan
+81 798 35 2980
info@dcservice.co.jp & www.dcs-asia.com

Korea

M.I. COFFEE CORPORATION
Seoul, South Korea
+ 82 592 0167
mi@micoffee.co.kr

Europe, Middle East, Africa

THE COFFEE ROASTING COMPANY APS
Copenhagen, Denmark
+45 3023 8775
jht@thefactorycoffee.eu

SCHEDULE A DEMO OR REQUEST A QUOTE AT LORING.COM



© 2025 Loring Smart Roast, Inc.
The following are trademarks of Loring Smart Roast, Inc.: Loring, The Smarter Way to Roast, S7 Nighthawk, S15 Falcon, S35 Kestrel, S70 Peregrine and the flame symbol. 1002697 Rev. J