

# LORING™ S7 Nighthawk™

## Think small.

### 1.4 – 7 kg

The Loring S7 Nighthawk takes the control and efficiency you've come to love in Loring roasters, and makes it available in a new smaller form factor. It offers 1.4 to 7 kg coffee roasting capacity in a compact 22 square foot space. Making it easier than ever to enjoy the benefits of owning a Loring roaster.



## Features & Benefits

- Patented single-burner design
  - » Smokeless roasting
  - » Fuel efficient
  - » Low NOx emissions
- Touchscreen with manual controls, and automated profile roasting software
- Automation to charge drum, discharge to cooler tray, run cooler tray fan and stirring arms
- 4 thermocouples: bean, return air, inlet air, and hot stack air temperatures
- Safety features include: self-cleaning roast chamber and exhaust stack; water quench into chaff barrel

<b>Technical Specifications</b>	
<b>Minimum Batch Capacity</b>	3 lb (1.4 kg)
<b>Maximum Batch Capacity</b>	15 lb (7 kg)
<b>Weight</b>	900 lb (410 kg)
<b>Stack temp continuous</b>	1400° F (760° C)
<b>Stack temp intermittent</b>	1500° F (816° C)
<b>Fuel</b>	Natural gas (NG) or propane
<b>BTU/hr (during roasting)</b>	75,000 (19,000 kcal/h)
<b>Electrical</b>	200 – 240 VAC, 50/60 Hz, single phase
<b>Touchscreen</b>	10-inch (diagonal) 1024 × 600 pixel (16:9)
<b>Materials (bean path and airflow)</b>	Stainless steel
<b>Cooler duct diameter</b>	6 in (152 mm)
<b>Hot stack duct diameter</b>	6 in (152 mm)

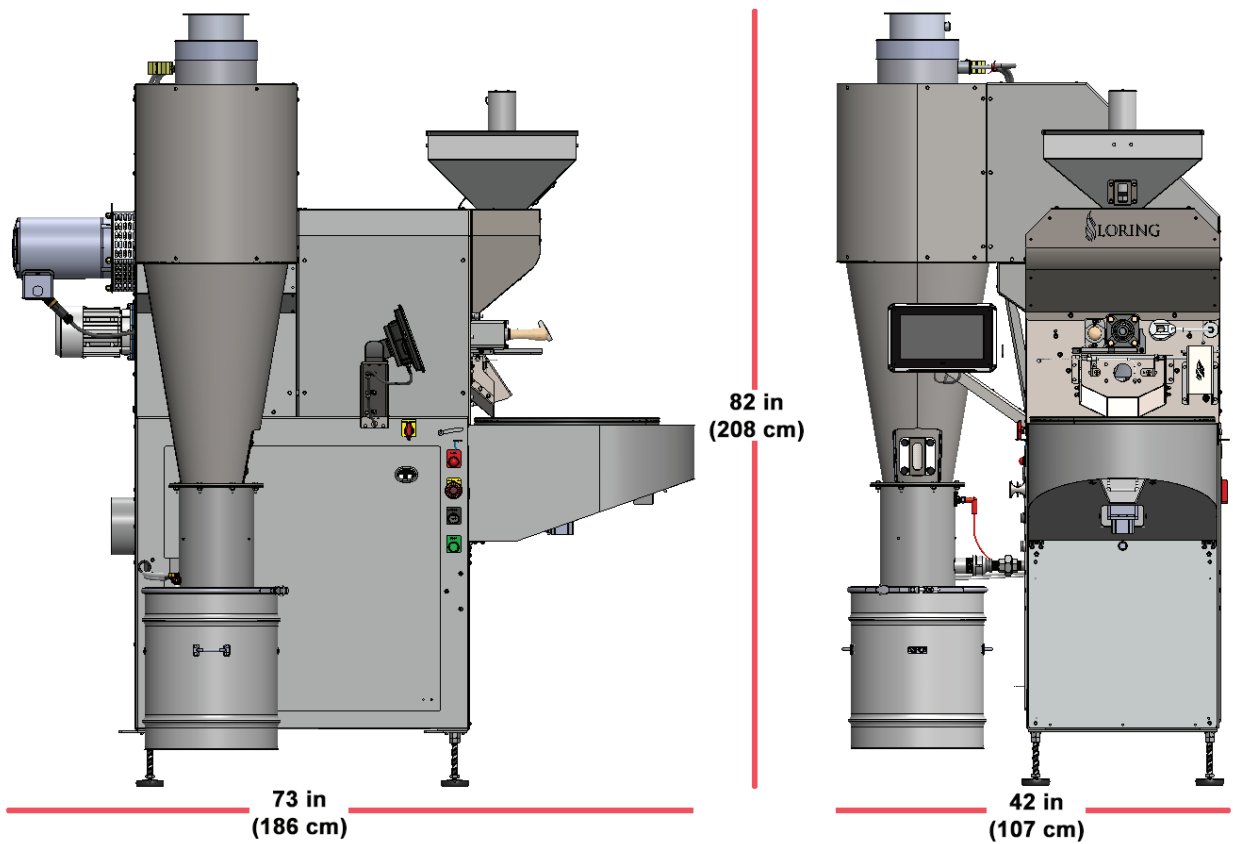

Features and specifications subject to change without notice.