

Installation Manual

Loring s70 Peregrine

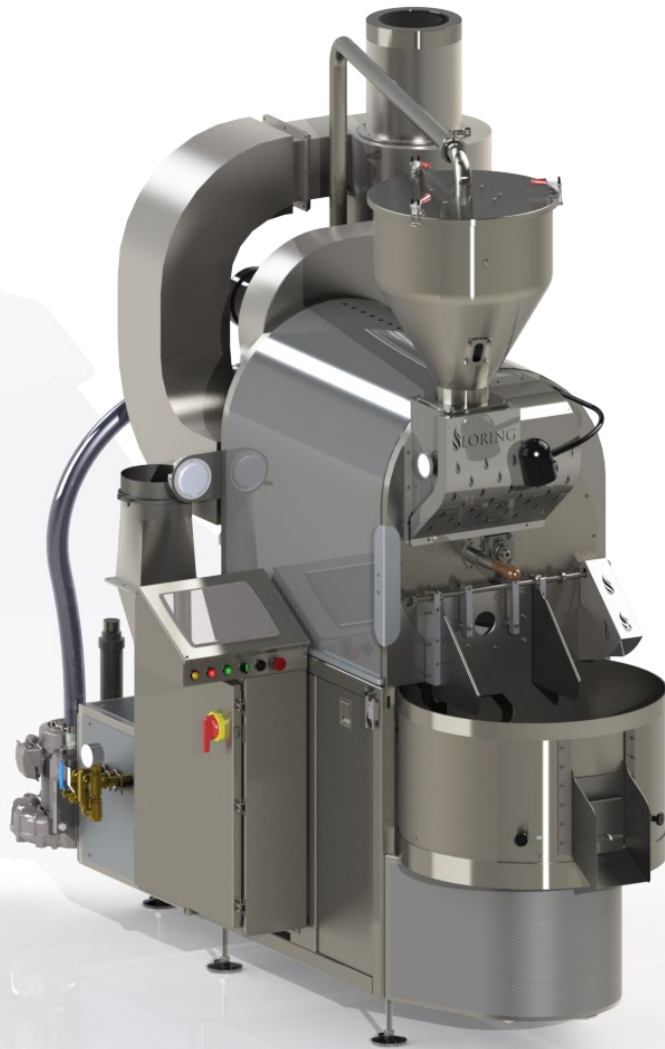

Loring Smart Roast, Santa Rosa CA, 95405

Installation manual

Loring Smart Roast

Loring S70 Peregrine Coffee Roaster

Revision A

May 20, 2015

Table of Contents

4. Disclaimer
5. Safety
6. Location
7. Placement
8. Stack Connections
9. Gas Connections
10. Electrical Connections
11. Water Connections
12. Air connections
13. Network connections
14. Appendix
15. Electrical Mains
17. MICDs drawings
19. Utility Tray
20. Hot Stack
21. Cooler Stack
22. Electrical
23. Network
24. Leveling Foot
25. Roaster Specifications

Disclaimer

This installation manual is intended to be a guideline for the installation of the Loring S70 Coffee Roaster.

It will be up to the customer to determine what local regulations apply to the Installation of the Roaster, what those regulations are and then follow them.

There are many other factors regarding the installation of the Roaster of which we will have no opinion as to its legality, functionality or appropriateness.

We as the manufacturer build this roaster to work in a “typical” installation, and can provide data of a typical installation, but can not guarantee that a “typical” installation will work in your situation.

In all instances, refer to a professional, licensed and qualified contractor for all Installation details.

Safety

Always use a professional, licensed and qualified contractor for all installation details.

Read and understand all manuals provided by the manufacturer before Beginning the installation task.

Always work in a clean, well lit area, segregated from other work processes.

Use the proper tools and techniques for all tasks.

Do not rush or cut corners on any aspect of the installation.

Wear proper personal protective equipment in accordance with local regulations and your own best practices.

Roaster Location

When determining the location for your new roaster, there are many things to think of.

The Loring S35 Kestrel will be a beautiful showpiece in your roastery, so be sure it is visible if possible.

Work flow. Consider how to position the roaster to integrate well with the rest of your business, taking into consideration proximity to green, grinders and other process equipment.

Lighting. A well lit work area is very important to any job, especially for a complex operation like roasting coffee.

Safety. Be sure that your roasting area is free from traffic including forklifts.

Ventilation. The roaster does not emit smoke, but does get warm, so proximity to ventilation may be important during warm weather.

Clearance. Please refer to the drawings attached in the back of this manual for minimum recommended clearances. It may seem like a good idea to have the roaster tight in its space, but when the time comes to work on it, you may find yourself in an uncomfortable position.

Placement

The roaster should be placed on a level, solid and cleanable work surface.

The ball swivel mount leveling feet will allow the roaster to be leveled after it is put in to position.

There may be regulations in your area which will mandate surface structure, anchoring and minimum clearances.

Compliance with all applicable regulations and codes will be the responsibility of the owner of the equipment.

Stack connections

Hot Stack

The Hot stack connects to the top of the cyclone to the 316 stainless steel “Stack Hat” we provide with the roaster. From this stack hat you can attach to the customer supplied stack by welding, clamping, screwing, riveting and caulking. No amount of leakage is acceptable.

The cap on the exit of the stack must keep all rain out of the stack.

You will need to refer to your ventilation contractor for the preferred method of attachment. In turn, your ventilation contractor will need to be sure to comply to all applicable local and regional regulations regarding installations of this type.

Cooler Stack

The cooler stack will attach to the top of the cooler housing outlet, typically with a v-band to a flange fitting, or at the preference of the customer and contractor may be attached by a variety of other methods. It is important that this connection is sealed but also easily removable for cleaning. The roaster may have the optional 45 degree offset kit, which does not alter the connection type, but allows for an easily removable and cleanable section.

The cap on the exit of the stack must keep all rain out of the stack.

You will need to refer to your ventilation contractor for the preferred method of attachment. In turn, your ventilation contractor will need to be sure to comply

Gas Connections

On the utility tray of the roaster is provided a NPT pipe fitting, which is the inlet to the burner assembly. There is a shut off valve provided at the roaster as well as a gauge for monitoring the incoming gas pressure.

There are a variety of installation methods available to the gas contractor, and the implementation will need to be determined by the contractor. It will be the responsibility of the contractor to not only be sure that the connections meet local code guide lines but also will supply the BTU/HR demand of the roaster. Improper connection type and pipe size will cause the roaster to perform poorly, potentially rendering it unusable. The gas contractor will be able to verify the potential BTU/HR of the supply system he installs based on pipe size, length, path and available pressure.

A separate regulator may be required to feed the roaster if the upstream pressure is too high.

Multiple fittings or a long path may reduce flow. This must be taken into consideration.

It is vital to the proper operation of the roaster as well as the safety and legality of the system that proper care and planning go into the gas supply system.

The contractor will provide the knowledge and experience to be sure you are in compliance but it is ultimately the responsibility of the owner of the roaster to be sure that the installation meets all applicable local and regional regulations regarding installations of this type.

Electrical Connections

All electrical connections to the roaster must be made by a local contractor in accordance to all applicable local and regional regulations regarding installations of this type.

Please refer to the diagrams in the back of this manual for a connection diagrams and further information applicable to your roaster installation.

Water connections

All water connections to the roaster must be made by a licensed contractor in accordance to all applicable local and regional regulations regarding installations of this type.

Water connection is available at the roaster. There is a shut off valve supplied as well as a pressure gauge to monitor water pressure.

No drain is required for the water as this water is provided as fire suppression to keep the chaff damp as well as provide emergency water in case of a chamber quench.

Air connections

All air connections to the roaster must be made by a licensed contractor in accordance to all applicable local and regional regulations regarding installations of this type.

An air connection is available at the roaster. There is a shut off valve supplied as well as a pressure gauge to monitor air pressure.

Network connections

The Loring roaster utilizes network connections internally to communicate among the various components. The same network connection is also available to the local area network, if connected. This gives the ability to communicate with external sources such as email.

The network must be configured using IP addresses, which will have been filled out on the PSF.

A single, live Ethernet cord plugged into the switch hub on the roaster will provide this connection.

Appendix

This section contains electrical connection diagrams, photographs of connection points and a data sheet specific for your roaster.

Installation Manual, Loring S70Coffee Roaster

Electrical MAINS



LORING SMART ROAST PROPRIETARY
 This document is controlled by Document Control. By printing this document, it will become a "Reference" copy.
 Users are responsible for verifying that it is the latest revision available

S70 Mains Power Wiring

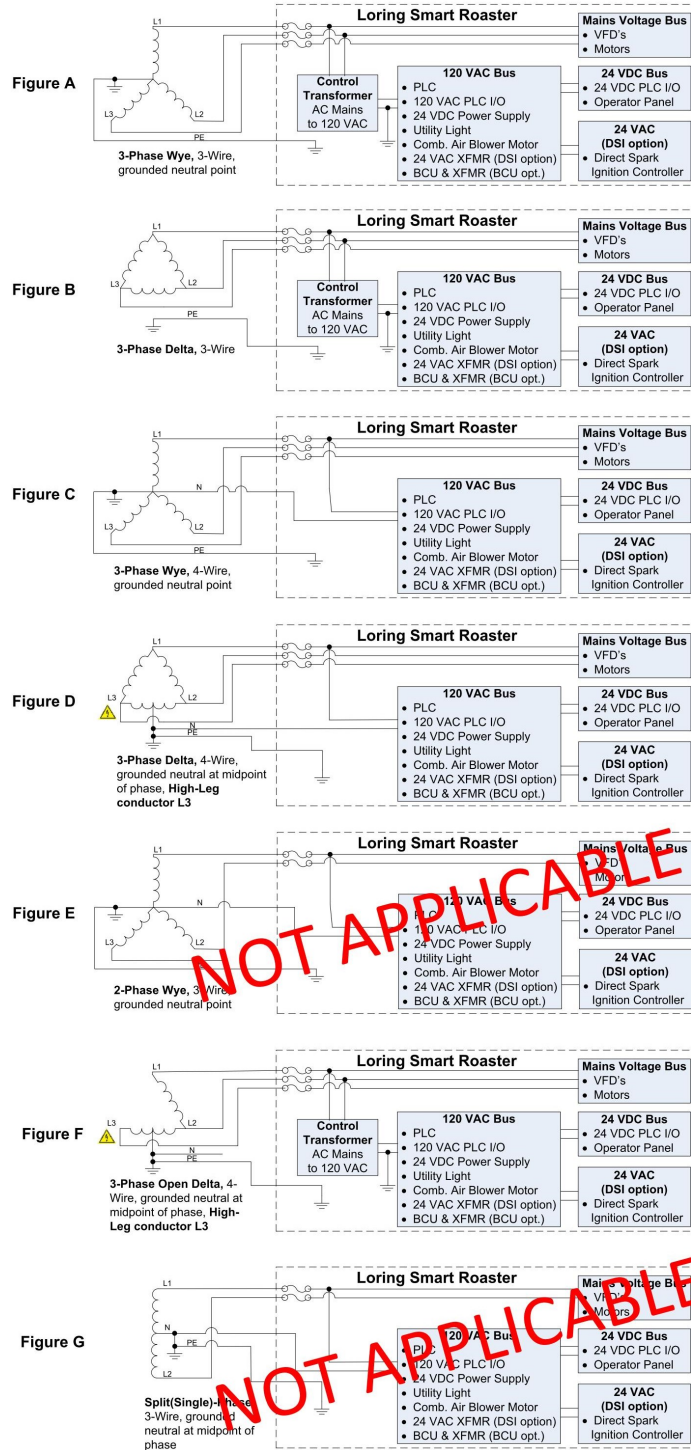

Document Owner: Engineering	Rev: A	Pg 1 of 2
-----------------------------	--------	-----------

Installation Manual, Loring S70 Coffee Roaster

Electrical MAINS



LORING SMART ROAST PROPRIETARY
 This document is controlled by Document Control. By printing this document, it will become a "Reference" copy.
 Users are responsible for verifying that it is the latest revision available.

S70 Mains Power Wiring

Model Number	Line-to-Line (L-L) Voltage [V]	Line-to-Neutral (L-N) Voltage [V] <1>	Roaster Amperage Service Rating [A]	Main Disconnect Fuse Type Littlefuse <2>	High-Leg/ Stinger-Leg/ Wild-Leg Voltage [V] <3>	Typical Wiring Topology Figure Letter	Recommended Supply Conductor Minimum Wire Gauge [AWG(mm ²)] <4>
200/100(3PD)	200	100	50	JTD50ID	173	F	08 (10.0)
208/120(3PY)	208	120	50	JTD50ID	-	C	08 (10.0)
208/XXX(3PY)	208	XXX	50	JTD50ID	-	A	08 (10.0)
220/110(3PD)	220	110	50	JTD50ID	190	D	08 (10.0)
230/XXX(3PY)	230	XXX	50	JTD50ID	-	A	08 (10.0)
240/120(3PD)	240	120	50	JTD50ID	208	D	08 (10.0)
380/220(3PY)	380	220	30	JTD30ID		A	10 (6.0)
400/230(3PY)	400	380	30	JTD30ID		A	10 (6.0)
415/240(3PY)	415	240	30	JTD30ID		A	10 (6.0)
480/277(3PY)	480	277	30	JTD30ID		A	10 (6.0)

<1> – If the facility does not have a neutral wire available, the Line-to-Neutral voltage is represented by "XXX".

<2> – The Littlefuse Inc (<http://www.littlefuse.com/jtd>) fuse ratings are: Time Delay, 600 VAC, 200 kA interrupt rating, Class J fuse.

<3> – On the Delta wiring topology with neutral, please note that one phase L-N voltage exceeds the other two by a factor of 1.73.

<4> - Wire gauge recommendations are per National Fire Protection Agency (NFPA) 79, *Electrical Standard for Industrial Machinery*, and NFPA 70, *National Electric Code*. However, installation shall be done by a locally licensed entity and shall follow the local codes and laws of the local governing agency.

- A dedicated ground (PE) wire is **required** (see table above for Recommended Wire Gauge) to be installed from the power source to the roaster and should be terminated into the ground (PE) lug adjacent to the main disconnect .
- On systems that have a dedicated neutral wire (see table above for Recommended Wire Gauge) from the power source, the neutral wire shall be terminated into one of the white terminal blocks located on the terminal strip in the main electrical cabinet.

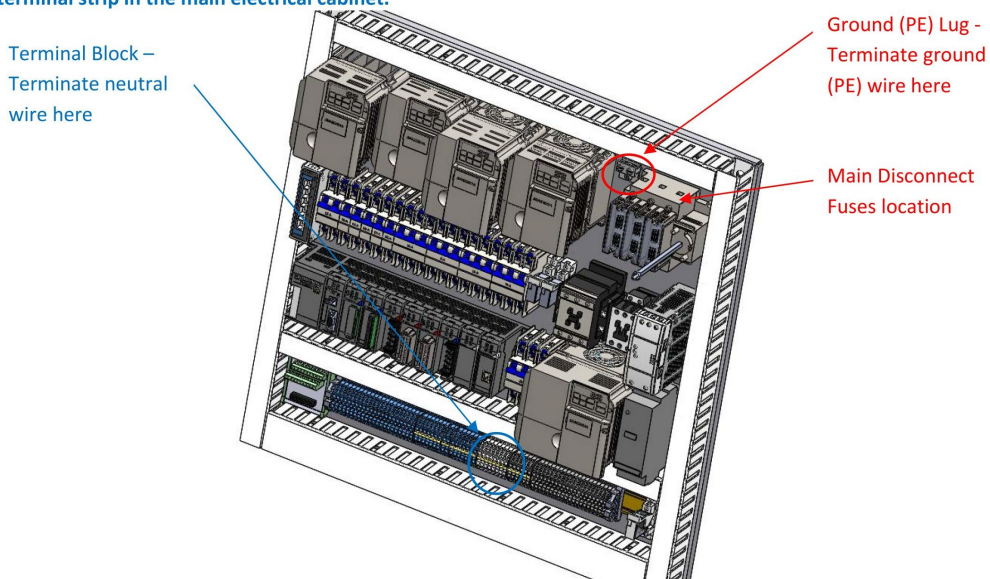

Document Owner: Engineering		
Doc No: 1001441	Rev: A	Pg 2 of 2

Installation Manual, Loring S70 Coffee Roaster

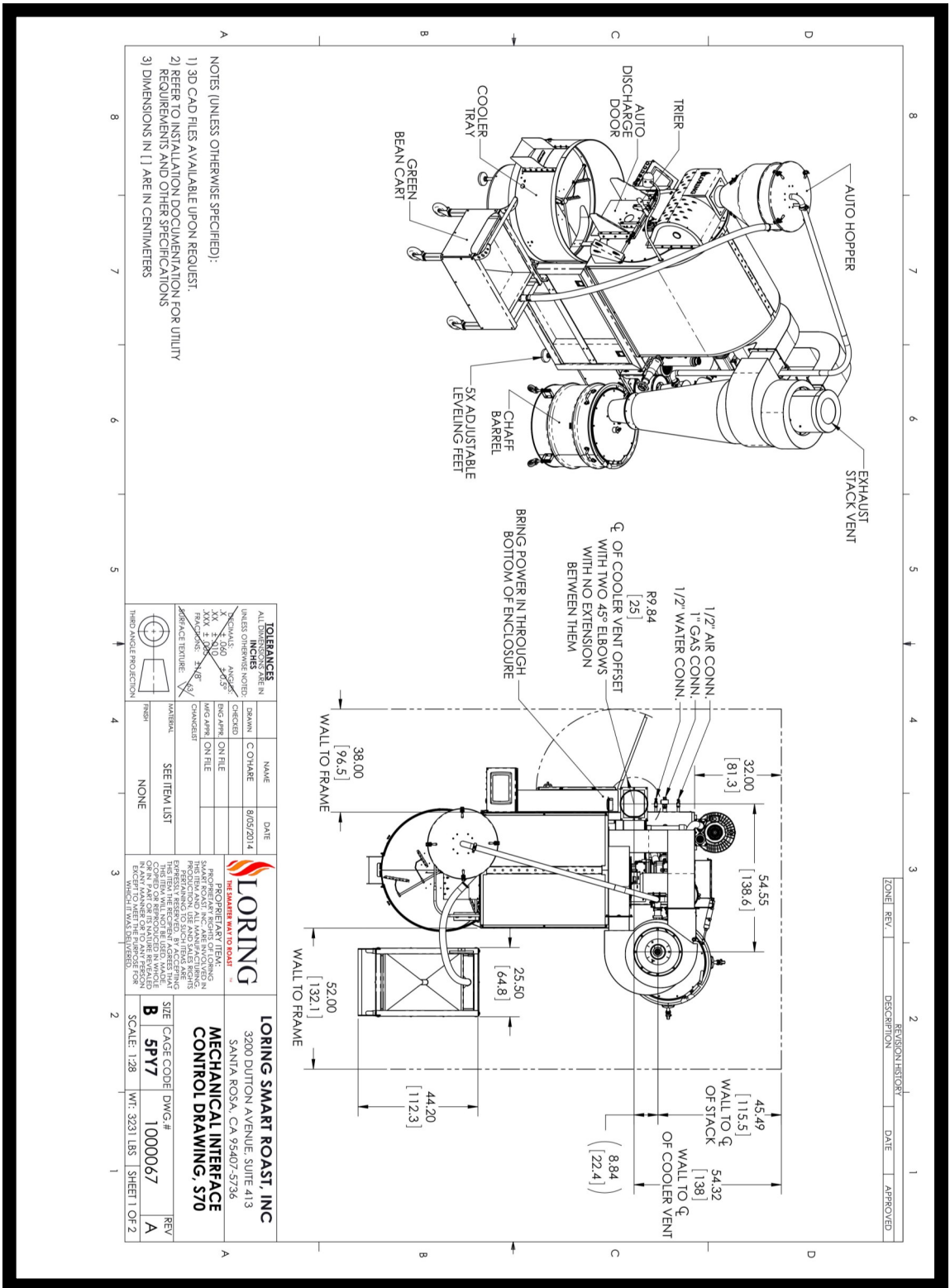

- NOTES (UNLESS OTHERWISE SPECIFIED):
- 1) 3D CAD FILES AVAILABLE UPON REQUEST.
 - 2) REFER TO INSTALLATION DOCUMENTATION FOR UTILITY REQUIREMENTS AND OTHER SPECIFICATIONS
 - 3) DIMENSIONS IN [] ARE IN CENTIMETERS

TOLERANCES UNLESS OTHERWISE NOTED		DATE	
INCHES	MILLIMETERS	DESIGNED BY	DATE
XX	±.001	C. CHAHAR	8/05/2014
XX	±.002	ENGINEER	
XX	±.005	CHECKED	
XX	±.010	MANUFACTURER	
XX	±.015	CONTRACTOR	
XX	±.020	INSTALLER	
XX	±.030	OPERATOR	
XX	±.040	MAINTENANCE	
XX	±.050	REPAIR	
XX	±.060	REPLACE	
XX	±.070	REBUILD	
XX	±.080	REPAIR	
XX	±.090	REPLACE	
XX	±.100	REBUILD	

REVISION	DESCRIPTION	DATE	APPROVED
1			
2			
3			
4			
5			
6			
7			
8			

<p>LORING THE SMART WAY TO ROAST</p> <p>LORING SMART ROAST, INC 3200 DUTTON AVENUE, SUITE 413 SANTA ROSA, CA 95407-5736</p>	<p>MECHANICAL INTERFACE MECHANICAL DRAWING, S70</p> <p>SIZE: [CAGE CODE] DWG # [1000067] SCALE: 1:28 WT: 3231 LBS SHEET 1 OF 2</p>
---	--

Loring Smart Roast, Santa Rosa CA, 95405

Installation Manual, Loring S70 Coffee Roaster

Utility Connections, Air, Water and Gas



Loring Smart Roast, Santa Rosa CA, 95405

Hot Stack Vent Connection



Cooler Vent Connection



Electrical Connection

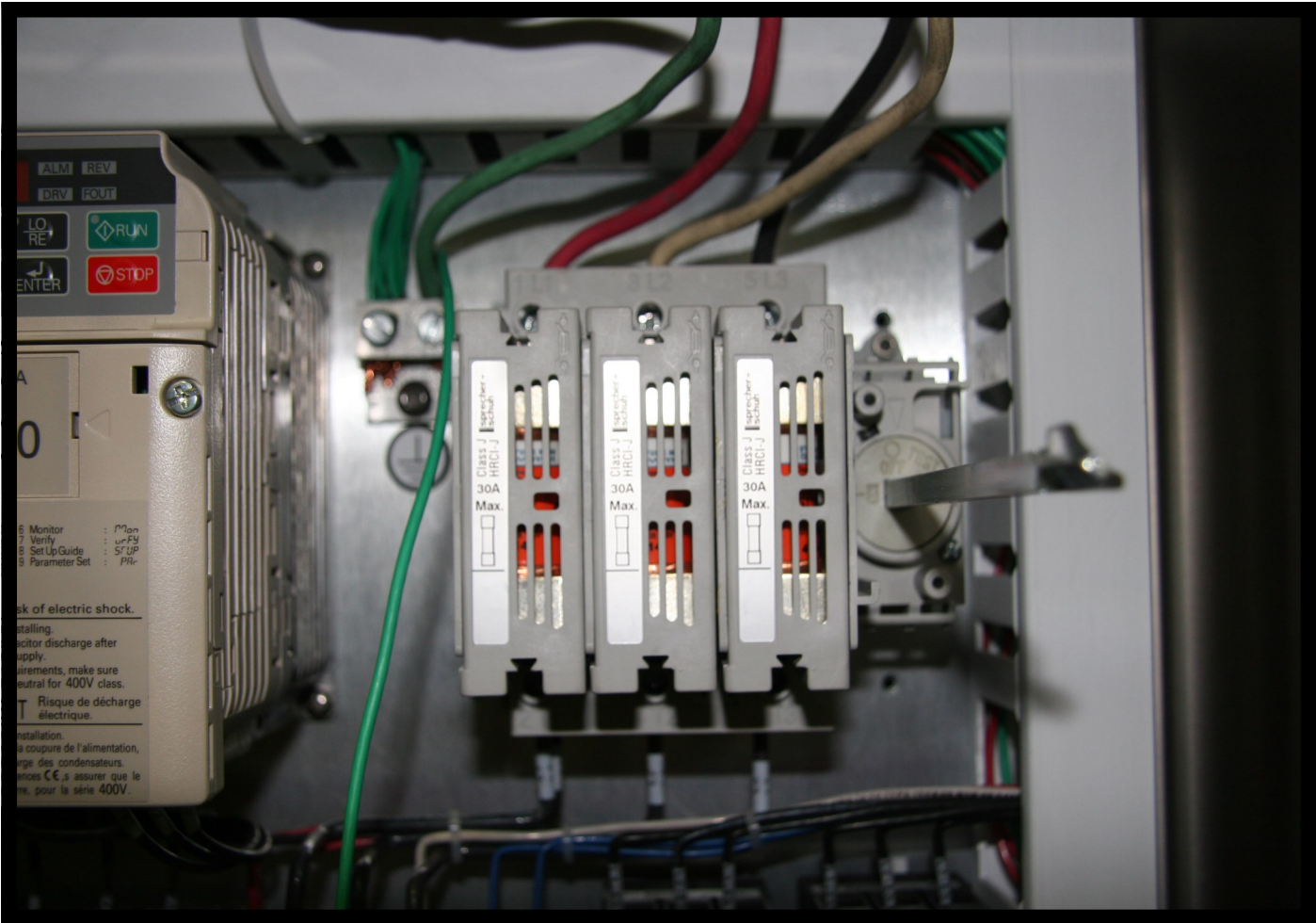

Network Connection



Leveling Foot



Roaster Data

Roaster Specifications	S70
Maximum Batch Size	154 lb (70 kg)
Minimum Batch Size	30.8 lb (14 kg)
Nominal Electrical Power	8.6 kW
Peak Electrical Power	17.5 kW
Maximum BTU Rating	600,000 BTU/h (151 K kcal/h)
Stack Max Continuous Temperature	1600 °F (871 °C)
Stack Max Intermittent Temp	1700 °F (927 °C)
Stack Max Flow	466 CFM (792 m3/h)
Stack Max Flow (Peak Air Cool)	966 CFM (1641 m3/h)
Stack Duct Diameter (Minimum)*	10 in (254 mm)
Stack Duct Wall Type	Double or Triple Wall 316 Stainless
Cooler Vent Max Flow	2200 CFM (3738 m3/h)
Cooler Duct Diameter	10 in (254 mm)
Water Supply	1 GPM (4 liter/min)
Water Pressure	50 psi (345 kPa)
Compressed Air Flow	4 CFM (0.11 m3/min)
Compressed Air Pressure	80 psi (552 kPa)
Natural Gas Pressure (+/-2 in WC)	7 in WC (2 kPa)
Propane Gas Pressure (+/-2 in WC)	11 in WC (3 kPa)
Weight	3000 lb (1361 kg)

Gas requirements

Gas specifications

Caloric Content

In order to provide adequate roasting performance, Loring roasters require that the gas supply maintain a minimum caloric level.

Natural gas:

1000Btu/ft³ (37 MJ/m³) or greater

Propane:

2500Btu/ft³ (93 MJ/m³) or greater

This is critical to the proper operation of the roaster. Confirm with your gas supply company that the minimum caloric content is supplied and constant.

Operating gas pressure

In order to provide proper burner operation it is critical that a constant operating pressure is available. Loring roasters require the following pressures to operate in all situations.

Natural gas:

4 in.WC to 7 in.wc (1.0 kPa to 1.7 kPa)

Propane:

11 in.WC to 14 in.WC (2.7kPa to 3.2 kPa)

A regulator or a combination of regulators may be needed to attain the proper operating pressure.